ABB DRIVES FOR WATER

ACQ580-31 drives

US Quick installation guide



List of related manuals in English

Drive manuals and guides	Code (English)
<i>ACQ580 pump control program firmware manual</i>	3AXD50000035867
<i>Quick start-up guide for ACQ580 pump control program</i>	3AXD50000048773
<i>ACQ580-31 hardware manual</i>	3AXD50000045935
<i>ACQ580-31 quick installation guide</i>	3AXD50000049859
<i>ACX-AP-x assistant control panels user's manual</i>	3AUA0000085685
Option manuals and guides	
<i>ACS580, ACH580 and ACQ580 drive module frames R3, R5 to R9 for cabinet installation (options +P940 and +P944) supplement</i>	3AXD50000210305
<i>ACS880-11, ACS880-31, ACH580-31 and ACQ580-31 UK gland plate (+H358) installation guide</i>	3AXD50000110711
<i>CDPI-01 communication adapter module user's manual</i>	3AXD50000009929
<i>FCAN-01 CANopen adapter module user's manual</i>	3AFE68615500
<i>FCNA-01 ControlNet adapter module user's manual</i>	3AUA0000141650
<i>FDNA-01 DeviceNet™ adapter module user's manual</i>	3AFE68573360
<i>FECA-01 EtherCAT adapter module user's manual</i>	3AUA0000068940
<i>FENA-01/-11/-21 Ethernet adapter module user's manual</i>	3AUA0000093568
<i>FEPL-02 Ethernet POWERLINK adapter module user's manual</i>	3AUA0000123527
<i>FPBA-01 PROFIBUS DP adapter module user's manual</i>	3AFE68573271
<i>FSCA-01 RS-485 adapter module user's manual</i>	3AUA0000109533
Tool and maintenance manuals and guides	
<i>Drive composer PC tool user's manual</i>	3AUA0000094606
<i>Converter module capacitor reforming instructions</i>	3BFE64059629
<i>NETA-21 remote monitoring tool user's manual</i>	3AUA0000096939
<i>NETA-21 remote monitoring tool installation and start-up guide</i>	3AUA0000096881

You can find manuals and other product documents in PDF format on the Internet.

See section [Document library on the Internet](#) on the inside of the back cover. For manuals not available in the Document library, contact your local ABB representative.

The code below opens an online listing of the manuals applicable to this product.



[ACQ580-31 manuals](#)

EN – US quick installation guide

This guide briefly describes how to install the drive. For complete information on installation, see *ACQ580-31 drives hardware manual* (3AXD50000045935 [English]). For cabinet installation, see also *ACS580, ACH580 and ACQ580 drive module frames R3, R5 to R9 for cabinet installation (options +P940 and +P944) supplement* (3AXD50000210305 [English]). For start-up instructions, see *ACQ580 drives with pump control program quick start-up guide* (3AXD50000048773 [English]).

To read a manual, go to abb.com/drives/documents and search for the document number.

Obey the safety instructions



WARNING! Obey these instructions. If you ignore them, injury or death, or damage to the equipment can occur:

- Only qualified electrical professionals are allowed to install and maintain the drive.
 - Never work on the drive, motor cable or motor when main power is applied. If the drive is already connected to the input power, wait for 5 minutes after disconnecting the input power.
 - Never work on the control cables when power is applied to the drive or to the external control circuits.
 - Do not connect the drive to a voltage higher than what is marked on the type designation label.
 - Always ground the drive, the motor and adjoining equipment to the protective earth (PE) bus of the power supply.
 - Frames R6 and R8: The drive module is heavy and its center of gravity is high. Use a lifting device for lifting. Do not tilt the drive. Manual lifting, or overturning due to the tilting, can cause physical injury. Make sure that the wall and the fixing devices can carry the weight.
 - Make sure that debris from drilling, cutting and grinding does not enter the drive.
 - Make sure that the floor below the drive and the wall where the drive is installed are non-flammable.
-

Check if capacitors need to be reformed

If the drive has not been powered up (either in storage or unused) for over three years, you must reform the capacitors.

You can determine the manufacturing date from the serial number, which you find on the type designation label attached to the drive. The serial number is of format **XYWWRXXXX**. **YY** and **WW** tell the manufacturing year and week as follows:

YY: 17, 18, 19, ... for 2017, 2018, 2019, ...

WW: 01, 02, 03, ... for week 1, week 2, week 3, ...

For information on reforming the capacitors, see *Converter module capacitor reforming instructions* (3BFE64059629 [English]), available on the Internet at abb.com/drives/documents.

Data

IEC ratings

ACQ580-31-	Cu cable (AWG/kcmil)	UL fuse	Losses (W)
3-phase $U_N = 480\text{ V}$			
09A5-4	14	JJS-15	219
12A7-4	14	JJS-20	278
018A-4	14	JJS-25	321
026A-4	10	JJS-35	473
033A-4	8	JJS-40	625
039A-4	8	JJS-50	711
046A-4	6	JJS-60	807
062A-4	4	JJS-80	960
073A-4	2	JJS-90	1223
088A-4	1/0	JJS-110	1560
106A4	2/0	JJS-150	1678
145A-4	3/0	JJS-200	2237
169A-4	250 MCM	JJS-225	2796
206A-4	300 MCM	JJS-300	3356

3AXD00000586715

UL (NEC) ratings

ACQ580-31-	Cu cable (AWG/kcmil)	UL fuse	Losses (W)
3-phase $U_N = 480\text{ V}$			
07A6-4	14	JJS-15	219
012A-4	14	JJS-20	278
014A-4	14	JJS-25	321
023A-4	10	JJS-35	473
027A-4	8	JJS-40	625
034A-4	8	JJS-50	711
044A-4	6	JJS-60	807
052A-4	4	JJS-80	960
065A-4	2	JJS-90	1223
077A-4	2	JJS-110	1560
096A-4	1/0	JJS-150	1678
124A-4	2/0	JJS-200	2237
156A-4	4/0	JJS-225	2796
180A-4	250 MCM	JJS-300	3356

3AXD00000586715

Select the power cables

See the [Data](#) table on page 4.

Ensure cooling

See the [Data](#) table on page 4. No condensation or frost is allowed. The allowed operating temperature range of the drive without derating is -15 to +40 °C.

Protect the drive and input power cable with correct fusing

Check on the fuse time-current curve to ensure that the operating time of the fuse is below 0.5 seconds for frames R3 and R6 and below 0.1 seconds for frame R8. Obey the local regulations.

A – Install the drive on the wall

See figure [A](#) on page 11.

Frames R6 and R8 of UL Type 12 (option +B056): Install an additional hood on top of the drive before you tighten the upper fastening screws. Place the vertical edge of the hood in between the wall and the drive back plate. Then tighten the screws to fasten the hood and drive on its place. See figure [A \(R6, R8\)](#) on page 11.

B – Remove the cover

Remove the cover(s). See figures [B \(R3\)](#) and [B \(R6, R8\)](#)... on page 11.

C – Check the compatibility with IT (ungrounded) and corner-grounded delta systems

See figure [C](#) on page 11.



WARNING! Do not install the drive with the EMC filter connected to a system that the filter is not suitable for. This can cause danger, or damage the drive. See the drive hardware manual.



WARNING! Do not install the drive with the ground-to-phase varistor connected to a system that the varistor is not suitable for. If you do, the varistor circuit can be damaged. See the drive hardware manual.

D – Check the insulation of the power cables and the motor

Check the insulation of motor and motor cable. See figure [D](#) on page [12](#). **Note:** Moisture inside the motor casing will reduce the insulation resistance. If moisture is suspected, dry the motor and repeat the measurement.

Check the insulation of the input cable before connecting it to the drive. Obey the local regulations.

E – Attach the warning stickers in local languages

See figure [E](#) on page [12](#).

F – Connect the power cables

Procedure:

1. Frames R6 and R8: Remove the shroud on the power cable terminals. See figure [F \(R6\)](#)... on page [12](#). Frame R8: For easier installation, remove the side plates.
2. Remove the rubber grommets from the bottom plate for the cable conduits to be installed. See figure [...F...](#) on page [12](#)
3. Attach the cable conduits to the bottom plate holes. See figure [...F...](#) on page [12](#).
4. Remove the cable shelves (4a). Reinstall the four screws to avoid moisture exchange through the empty holes! (4b). See figure [...F \(R6, R8\)](#)... on page [12](#).
5. Strip the cable ends. (Note the extra length of the grounding conductors.) Slide the cables through the connectors. See figure [...F...](#) on page [12](#).
6. Connect the grounding conductors to the grounding terminals. Connect the conductors of the input and motor cables. Tighten the screws. See figures [...F \(R3\)](#)..., [...F \(R6\)](#)... and [...F \(R8\)](#)... on page [12](#).

Connect the phase conductors of the motor cable to the T1/U, T2/V and T3/W terminals and the phase conductors of the input cable to the L1, L2 and L3 terminals.

If the protective PE conductor is smaller than 10 mm², you must use a second earthing conductor (6a). See the hardware manual for more information.

7. Frame R6 types -044A-4 and greater: Cut tabs in the shroud for the installed cables. Frame R8: Install the side plates if removed. Knock out holes in the shroud for the input cables. See figure [...F \(R6, R8\)](#)... on page [13](#).
 8. Frames R6 and R8: Install the shroud on the power cable terminals.
-

G – Connect the control cables

Procedure:

1. Remove the front cover(s) if not already removed.
2. Frame R3: Lift the control panel holder up. See figure [G \(R3\)](#)... on page [13](#).
3. Remove the rubber grommets from the bottom plate for the cable conduits to be installed.
4. Attach the cable conduits to the bottom plate holes.
5. Strip the cable ends and cut to suitable length (note the extra length of the grounding conductors).
6. Route the cables. Frame R3: See figure [...G \(R3\)](#)... on page [13](#).
Frame R6: See figure [...G \(R6\)](#)... on page [14](#). Frame R8: See figure [...G \(R8\)](#)... on page [14](#).
7. Secure the cables inside the drive with cable ties.
8. Ground the pair-cable shields and grounding wire at the grounding terminal (SCR) of the control unit.
9. Connect the conductors to the appropriate terminals of the control unit. See [Default IO connection diagram](#) on page [8](#).
10. Wire the optional modules if included in the delivery. See the option module user's manual or installation guide.

Note:

- Leave the other ends of the control cable shields unconnected.
- Keep any signal wire pairs twisted as close to the terminals as possible.

H – Reinstall cover(s)

See figures [H \(R3, R6, R8\)](#)... on page [15](#).

■ Default IO connection diagram

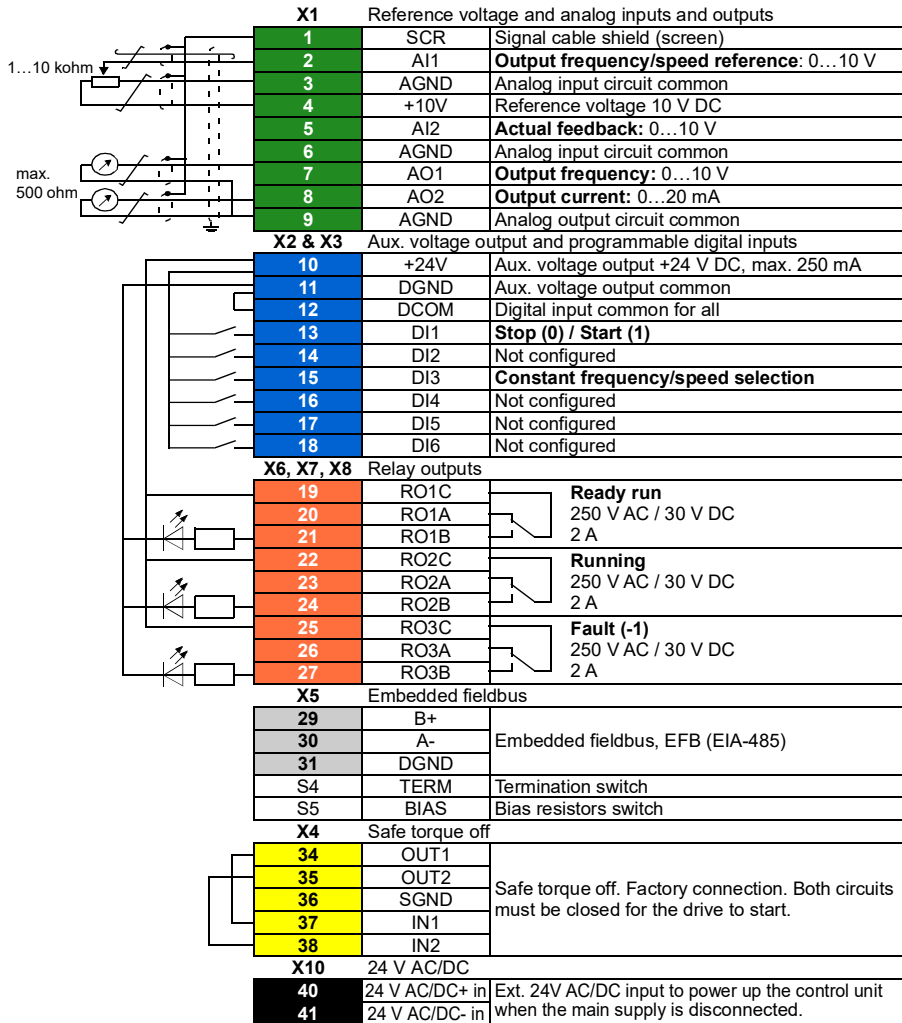

Total load capacity of the Auxiliary voltage output +24V (X2:10) is 6.0 W (250 mA / 24 V DC).

Wire sizes: 0.14...2.5 mm² (26...14 AWG): All terminals

Tightening torques: 0.5...0.6 N·m (0.4 lbf·ft)

UL checklist



WARNING! Operation of this drive requires detailed installation and operation instructions provided in the hardware and software manuals. The manuals are provided in electric format in the drive package or on the Internet. Retain the manuals with the drive at all times. Hard copies of the manuals can be ordered through the manufacturer.

- Make sure that the drive type designation label includes the cULus Listed marking.
- **CAUTION - Risk of electric shock.** After disconnecting the input power, always wait for 5 minutes to let the intermediate circuit capacitors discharge before you start working on the drive, motor or motor cable.
- The drive is to be used in a heated, indoor controlled environment. The drive must be installed in clean air according to enclosure classification. Cooling air must be clean, free from corrosive materials and electrically conductive dust. UL Type 12 (IP55) enclosure provides protection from airborne dust and light sprays or splashing water from all directions. See the hardware manual.
- The maximum surrounding air temperature is 50 °C (122 °F) at rated current. The current is derated for 40 to 50 °C (104 to 122 °F).
- The drive is suitable for use in a circuit capable of delivering not more than 100,000 rms symmetrical amperes, 480 V maximum when protected by the UL fuses on page 4. The ampere rating is based on tests done according to the appropriate UL standard.
- The cables located within the motor circuit must be rated for at least 75 °C (167 °F) in UL-compliant installations. For UL Type 12 drives of frame R6, the power cables must be rated for 90 °C (194 °F) minimum. For ambient temperatures above +40 °C (+104 °F), the power cables must be rated for 90 °C (194 °F) minimum.
- Integral solid state short circuit protection does not provide branch circuit protection. The input cable must be protected with fuses. Suitable UL (class T) fuses are listed on page 4. These fuses provide branch circuit protection in accordance with the National Electrical Code (NEC) and Canadian Electrical Code. For installation in the United States, obey any other applicable local codes. For installation in Canada, obey any applicable provincial codes.
- **Note:** Circuit breakers must not be used without fuses in the USA. Consult ABB for suitable circuit breakers.



WARNING! The opening of the branch-circuit protective device may be an indication that a fault current has been interrupted. To reduce the risk of fire

or electric shock, current-carrying parts and other components of the device should be examined and replaced if damaged.

- The drive provides motor overload protection. For the adjustments, see the firmware manual.
 - For the drive overvoltage category and pollution degree, see the hardware manual.
-

Figures USA



A

① ② ③

R3: M5 (#10)
R6: M8 (5/16")
R8: M8 (5/16")

x4

R6, R8	
kg	lb
≥61.0	≥134.51

B (R3)

UL Type 1

UL Type 12

② ①b ①a ①

...B (R6, R8)

UL Type 12

A (R6, R8)

UL Type 12

④

B (R6, R8)...

UL Type 1

UL Type 12

② ①b ①a ③

C

TN-S system

IT system

Corner-grounded delta system

Midpoint-grounded delta system

TT system

See the hardware manual

C

C

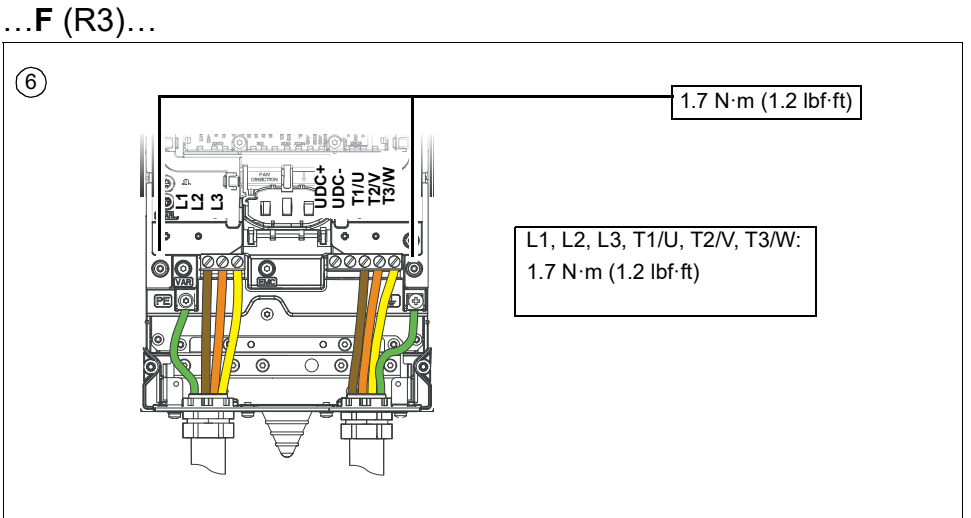
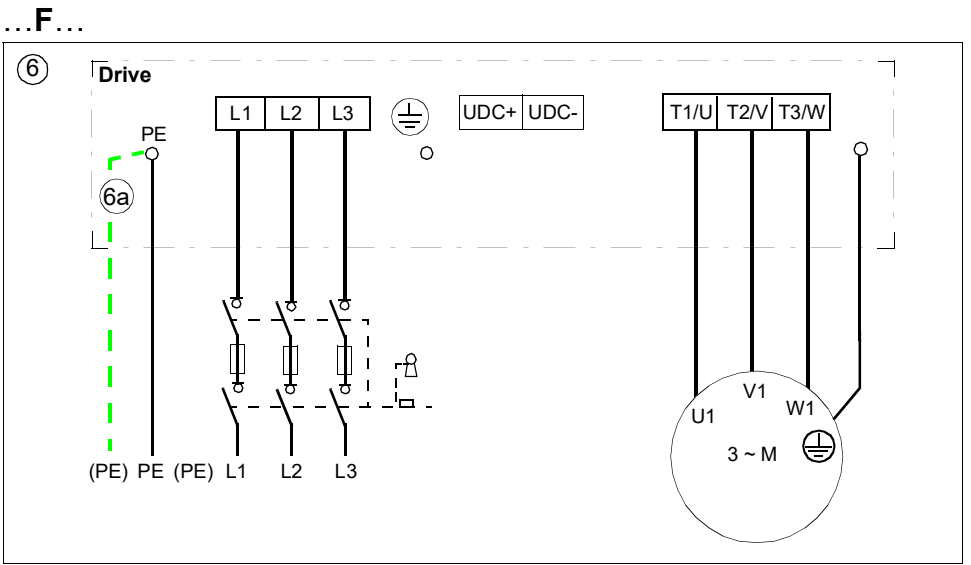
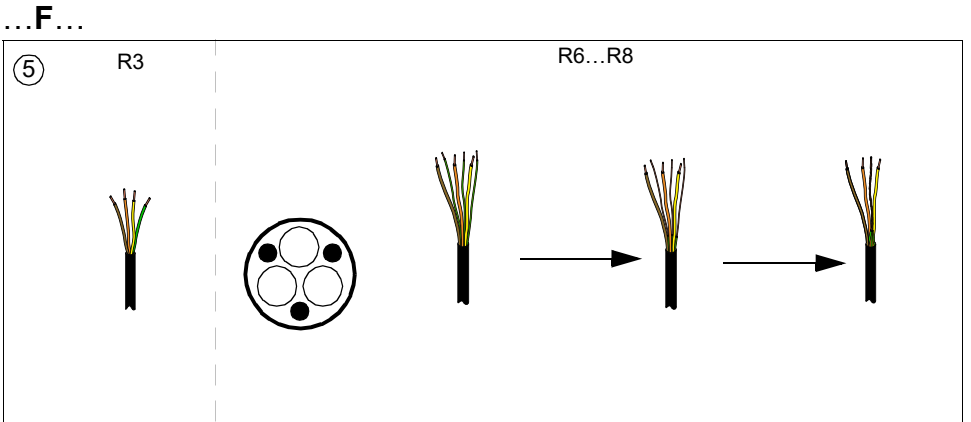
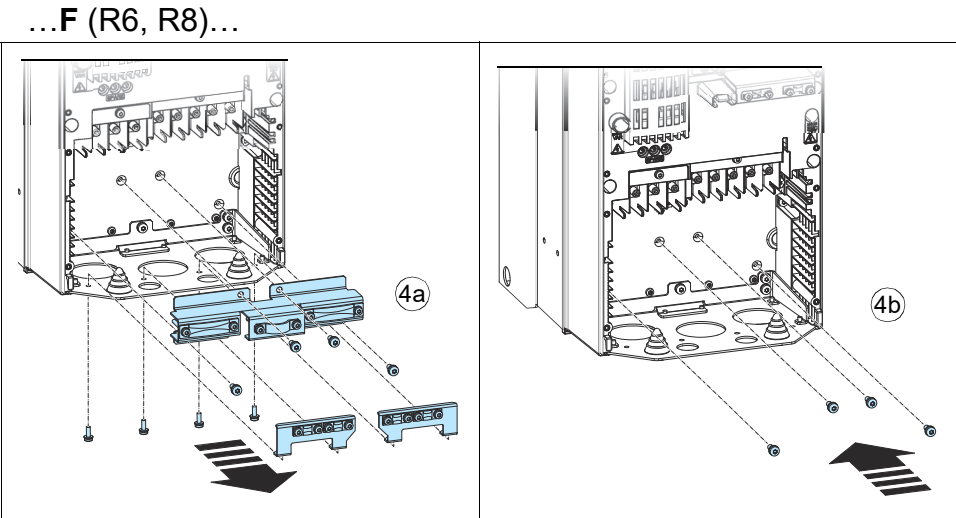
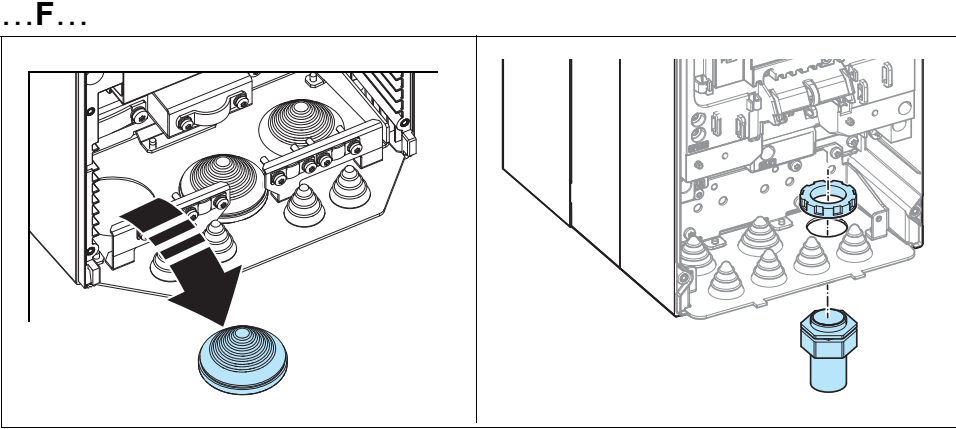
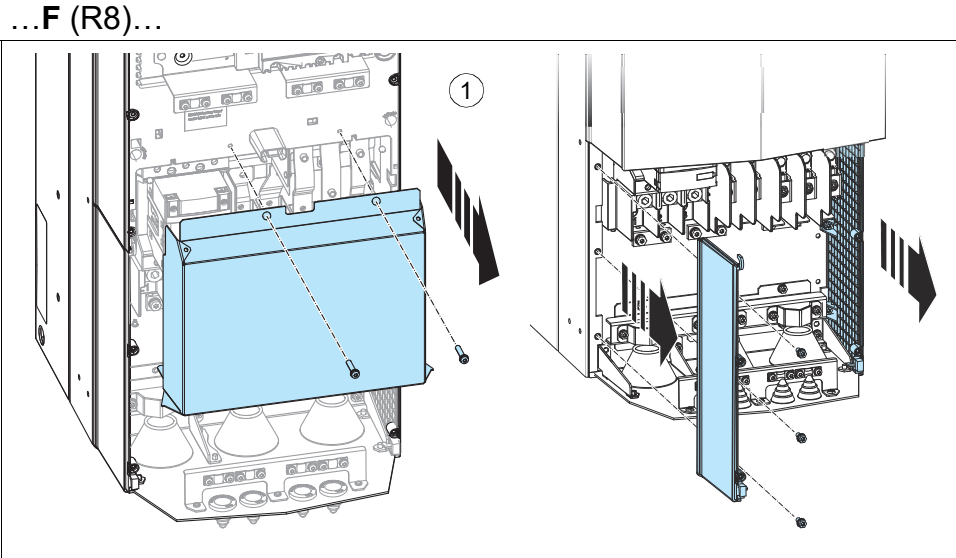
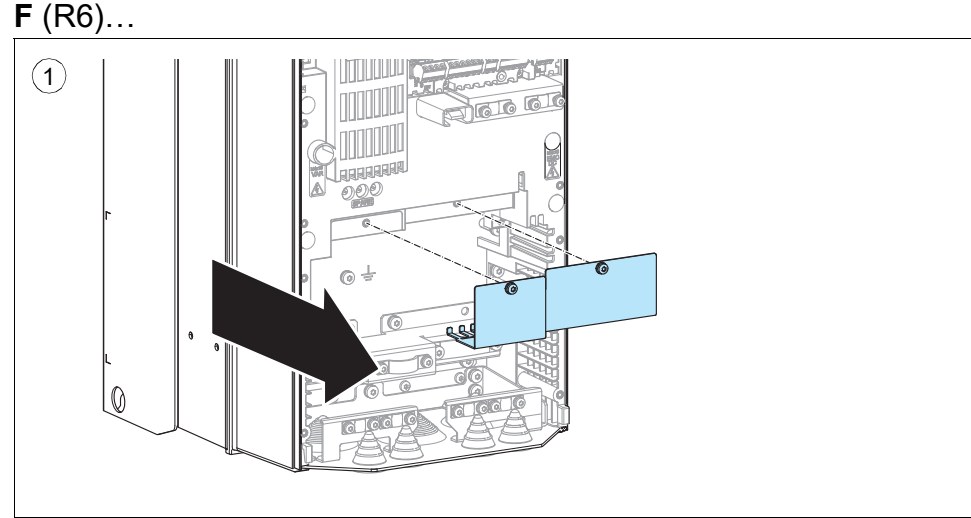
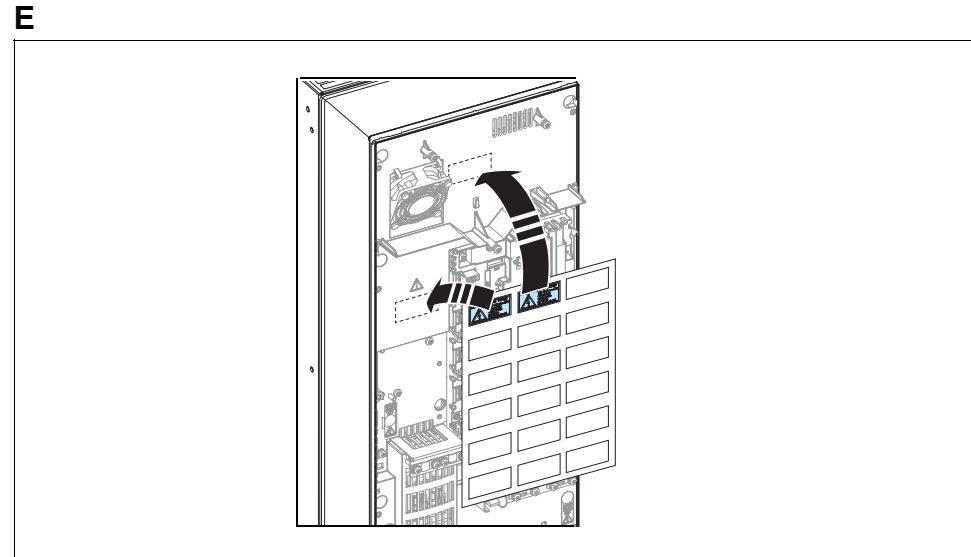
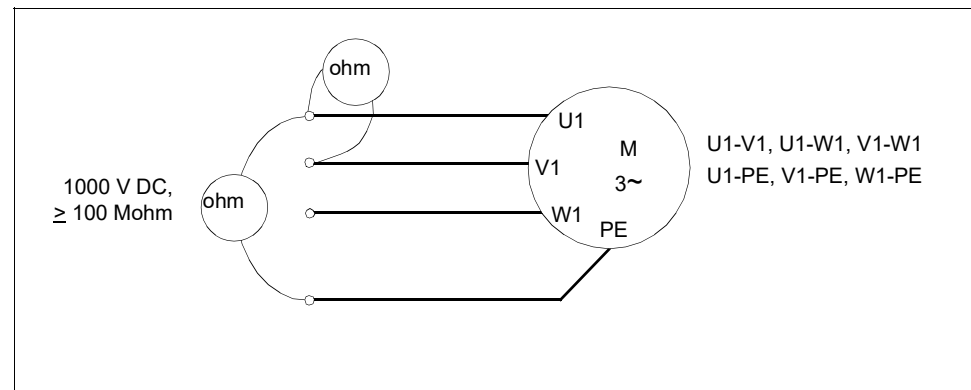

...F (R6)...

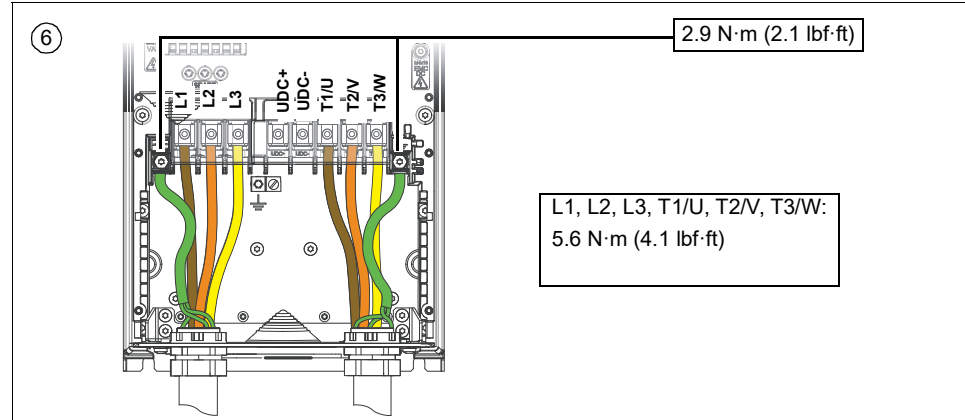

...F (R6, R8)...

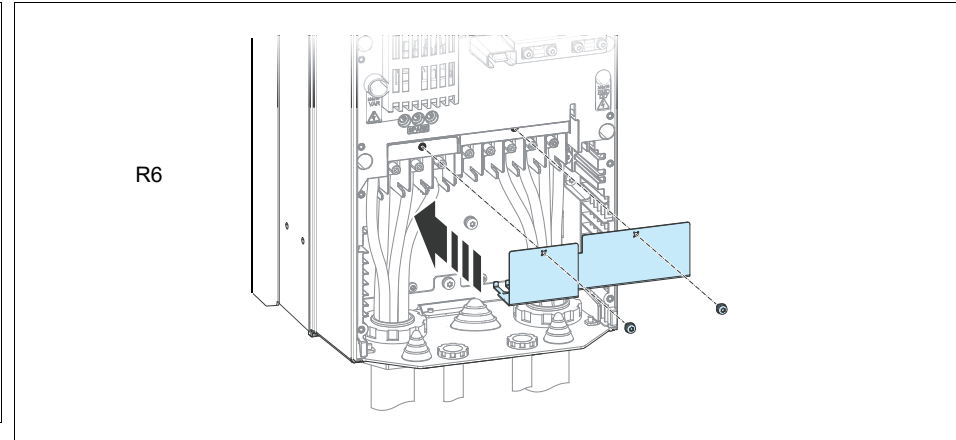

...F (R8)...

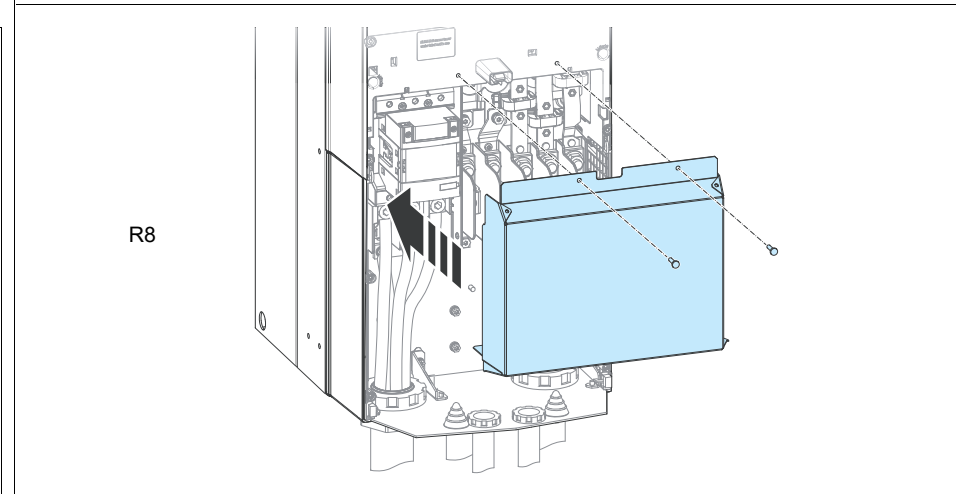
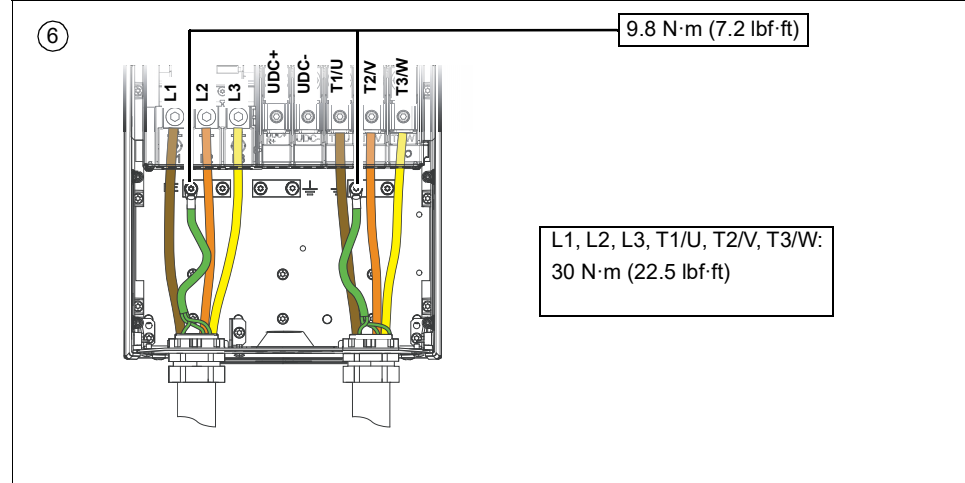

...F (R8)...

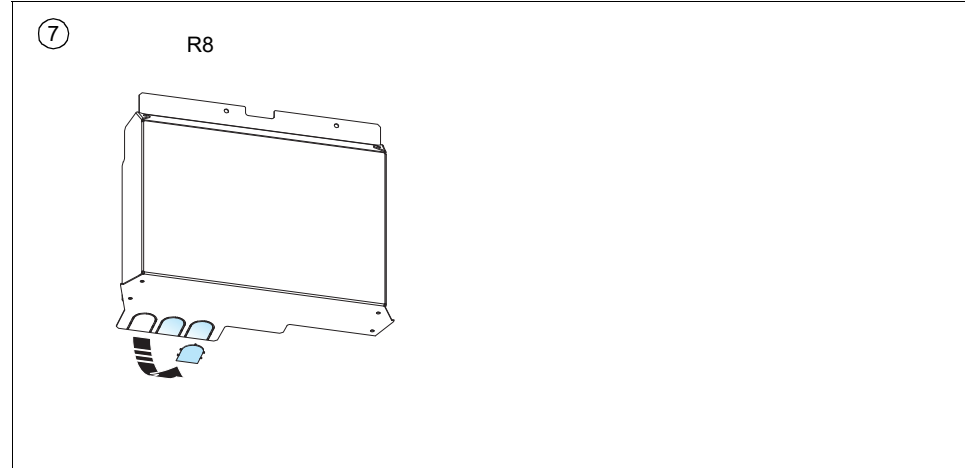

G (R3)...

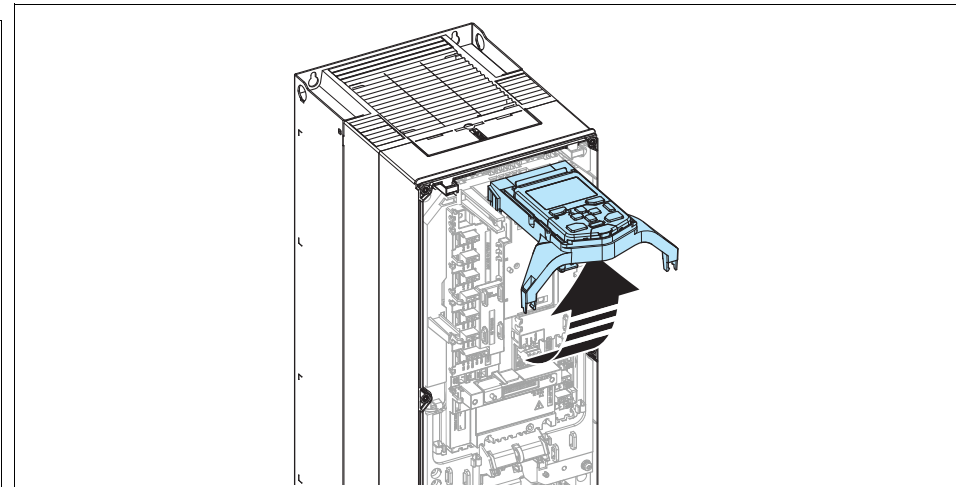

...G (R3)...

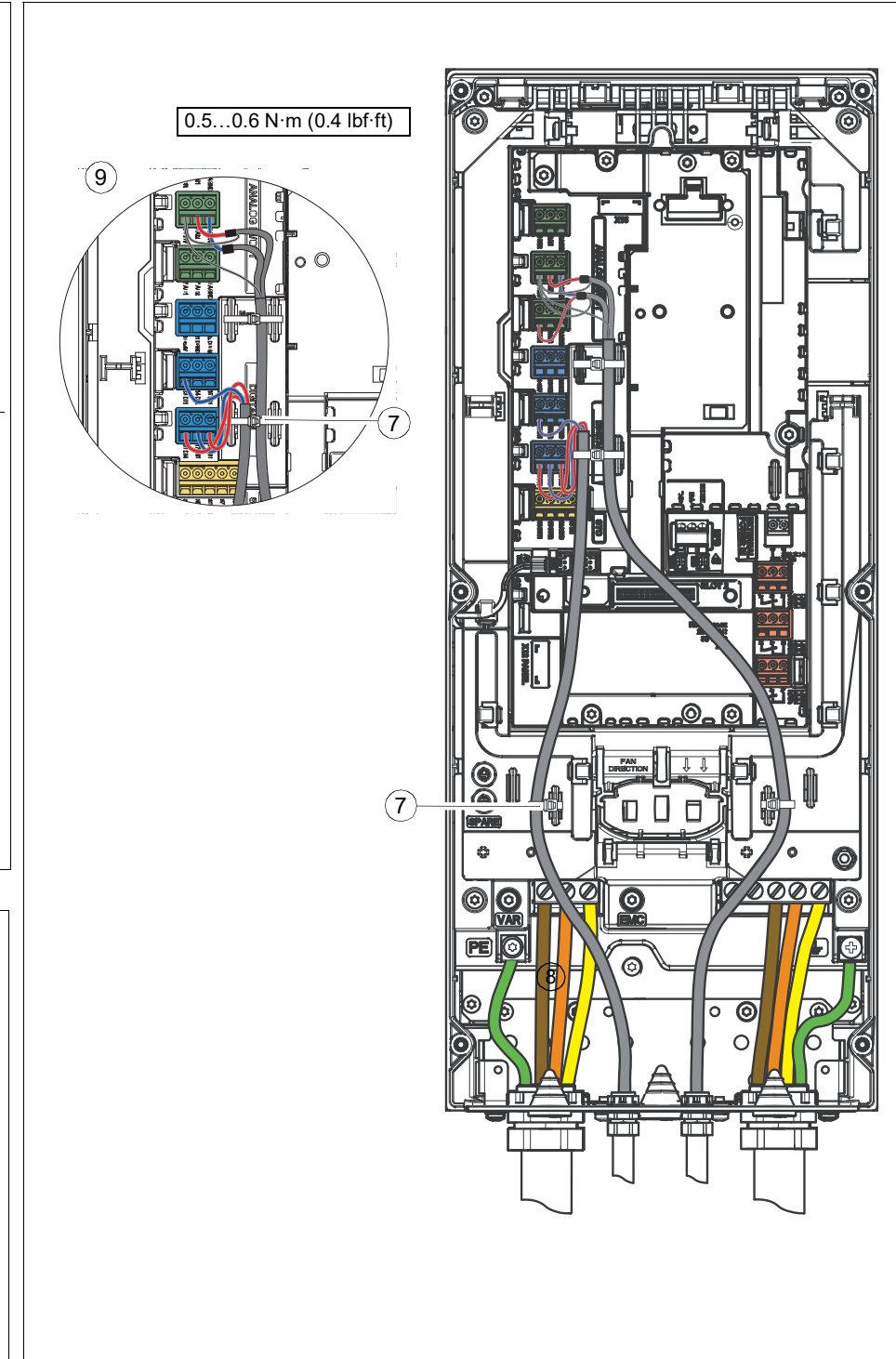

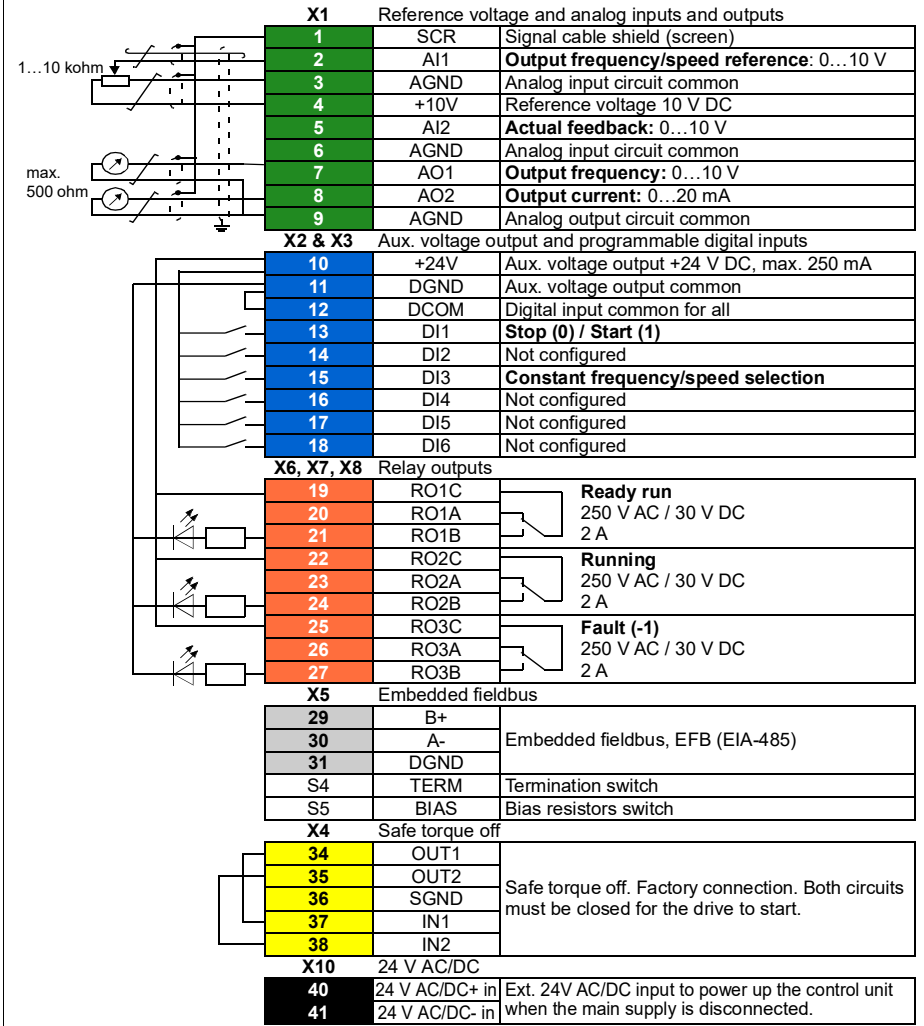
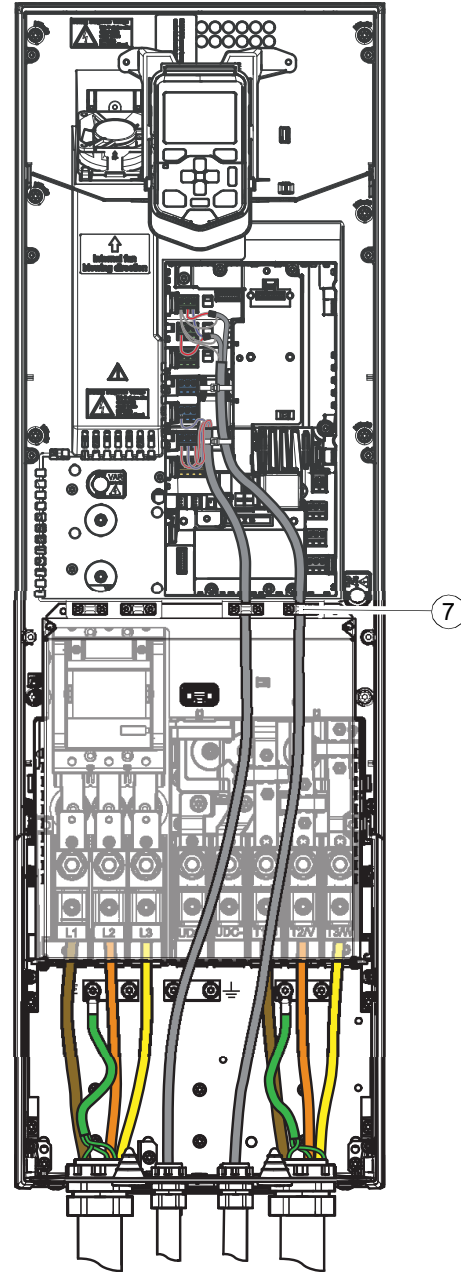
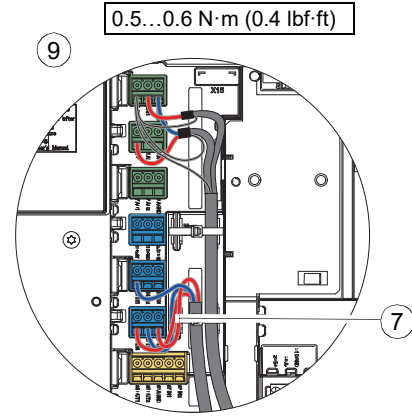
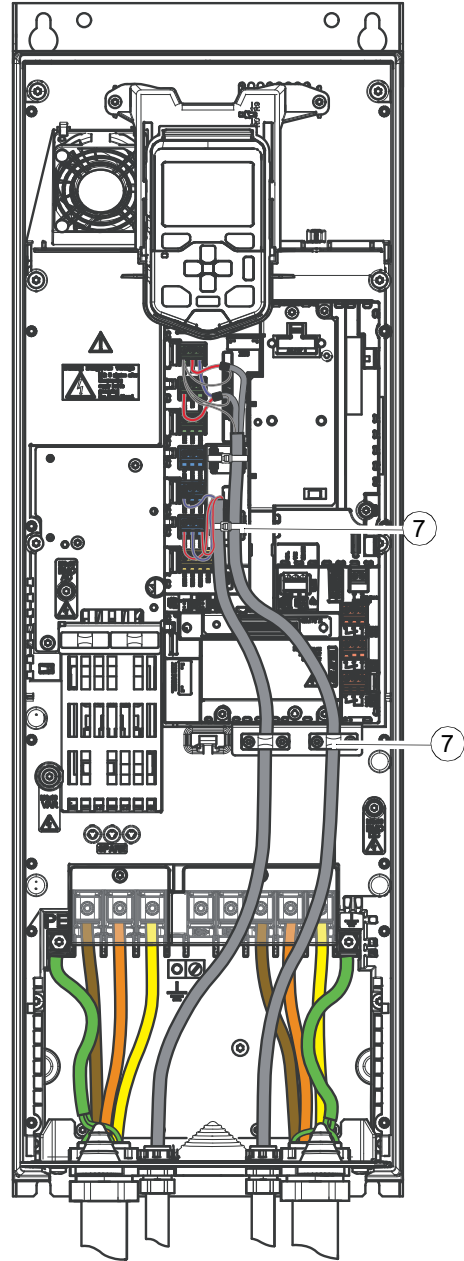
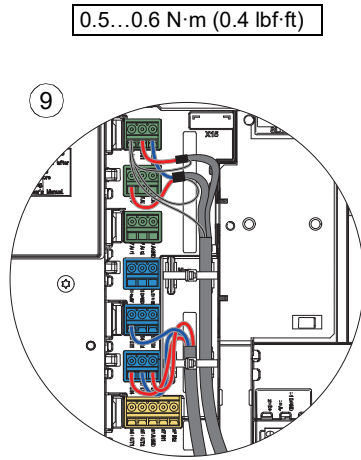

Total load capacity of the Auxiliary voltage output +24V (X2:10) is 6.0 W (250 mA / 24 V DC).
 Wire sizes: 0.14...2.5 mm² (26...14 AWG); All terminals
 Tightening torques: 0.5...0.6 N·m (0.4 lbf·ft)

H (R3, R6, R8)...

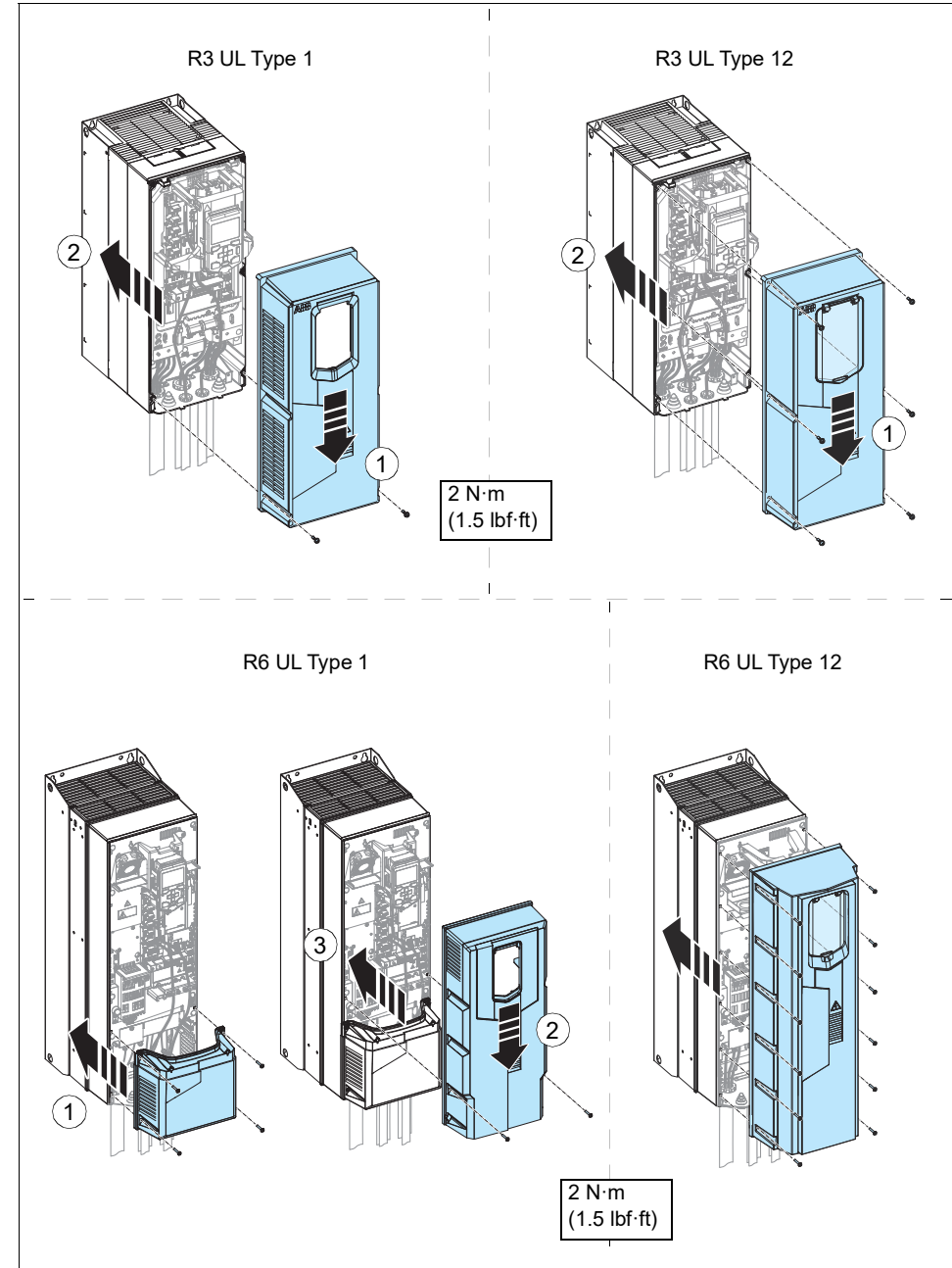

...H (R8)





ABB DRIVES FOR WATER

Quick start-up guide

Basic ACQ580 program setup

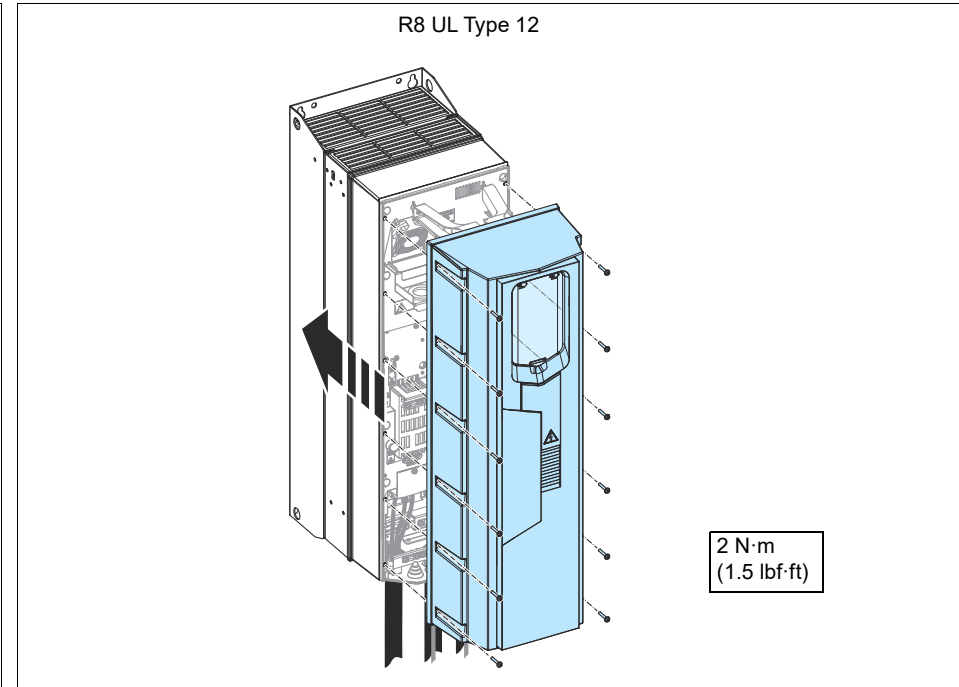
[Page intentionally left blank]









Quick start-up guide









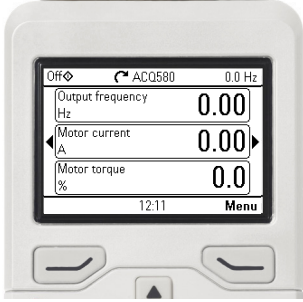

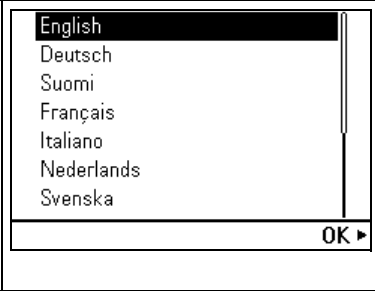

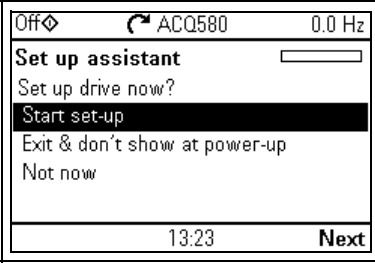

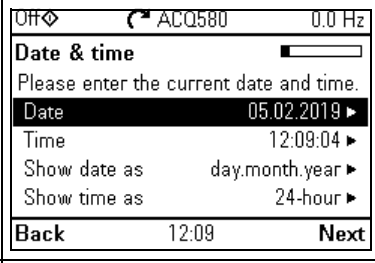

This guide describes how to start-up the drive using the First start assistant on the Hand-Off-Auto control panel. For complete information on start-up, see ACQ580 *firmware manual* (3AXD50000035867 [English]).

Before you start



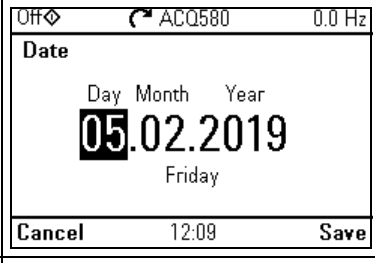



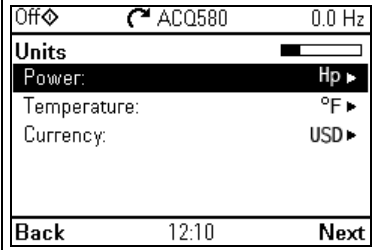

Ensure that the drive has been installed as described in chapter [R1...R4 Quick installation guide](#) on page 25 or in chapter [R5 Quick installation guide](#) on page 41 or in chapter [R6...R9 Quick installation guide](#) on page 53 of the ACQ580-01 *Quick Start Guide* (3AXD50000049128).

Start-up with the First start assistant on a Hand-Off-Auto control panel

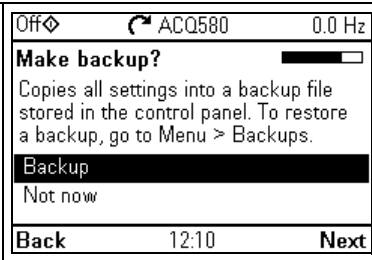

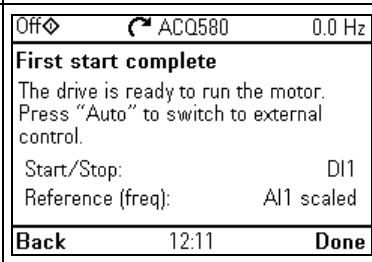

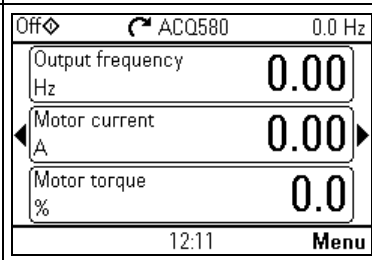







Safety	
<input type="checkbox"/>	Make sure that the installation work is complete. Make sure that cover of the drive and the cable box, if included, are on place.
<input type="checkbox"/>	 Check that the starting of the motor does not cause any danger. De-couple the driven machine if there is a risk of damage in case of an incorrect direction of rotation.
Hints on using the assistant control panel	
<p>The two commands at the bottom of the display (Options and Menu in the figure on the right), show the functions of the two softkeys  and  located below the display. The commands assigned to the softkeys vary depending on the context.</p> <p>Use keys , ,  and  to move the cursor and/or change values depending on the active view.</p> <p>Key  shows a context-sensitive help page.</p>	
1 – First start assistant guided settings: Language, date and time, and motor nominal values	
<input type="checkbox"/>	Have the motor or pump name plate data at hand. Power up the drive.

<p><input type="checkbox"/> The First start assistant guides you through the first start-up.</p> <p>The assistant begins automatically. Wait until the control panel enters the view shown on the right.</p> <p>Select the language you want to use by highlighting it (if not already highlighted) and pressing  (OK).</p> <p>Note: After you have selected the language, it takes a few minutes for the control panel to wake up.</p>	 <p>The screenshot shows a list of languages: English, Deutsch, Suomi, Français, Italiano, Nederlands, Svenska. The 'English' option is highlighted. At the bottom right, there is an 'OK' button with a right-pointing arrow.</p>
<p><input type="checkbox"/> Select Start set-up and press  (Next).</p>	 <p>The screenshot shows the 'Set up assistant' screen. It asks 'Set up drive now?' and has three options: 'Start set-up' (highlighted), 'Exit & don't show at power-up', and 'Not now'. At the bottom, it shows the time '13:23' and a 'Next' button.</p>
<p><input type="checkbox"/> Set the date and time as well as date and time display formats.</p> <ul style="list-style-type: none"> • Go to the edit view of a selected row by pressing . • Scroll the view with  and . <p>Go to the next view by pressing  (Next).</p>	 <p>The screenshot shows the 'Date & time' screen. It says 'Please enter the current date and time.' and has fields for 'Date' (05.02.2019), 'Time' (12:09:04), 'Show date as' (day.month.year), and 'Show time as' (24-hour). At the bottom, it shows 'Back' and 'Next' buttons.</p>
<p><input type="checkbox"/> To change a value in an edit view:</p> <ul style="list-style-type: none"> • Use  and  to move the cursor left and right. • Use  and  to change the value. • Press  (Save) to accept the new setting, or press  (Cancel) to go back to the previous view without making changes. 	 <p>The screenshot shows the 'Date' edit screen. It displays 'Day Month Year' and '05.02.2019' with 'Friday' below it. At the bottom, it shows 'Cancel' and 'Save' buttons.</p>
<p><input type="checkbox"/> Change the units shown on the panel if needed.</p> <ul style="list-style-type: none"> • Go to the edit view of a selected row by pressing . • Scroll the view with  and . <p>Go to the next view by pressing  (Next).</p>	 <p>The screenshot shows the 'Units' screen. It has three rows: 'Power:' with 'Hp' selected, 'Temperature:' with '°F' selected, and 'Currency:' with 'USD' selected. At the bottom, it shows 'Back' and 'Next' buttons.</p>

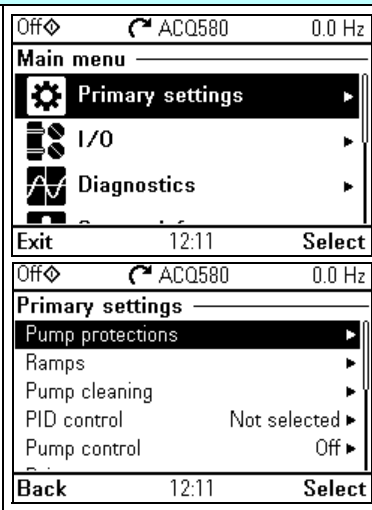
<p><input type="checkbox"/> To give the drive a name that will be shown at the top, press .</p> <p>If you do not want to change the default name (ACQ580), continue by pressing (Next).</p> <p>For information on editing text, see <i>ACQ580 firmware manual</i> (3AXD50000035867 [English]).</p> <p>Hint: Name the drive, for example, Pump 1.</p>																																																																																																																									
<p>Refer to the motor or pump nameplate for the following nominal value settings of the motor. Enter the values <u>exactly</u> as shown on the motor or pump nameplate.</p>																																																																																																																									
<p>Example of a nameplate of an induction (asynchronous) motor:</p> <table border="1" data-bbox="109 491 535 877"> <thead> <tr> <th colspan="8">ABB Motors</th> </tr> <tr> <td colspan="8">3 ~ motor M2AA 200 MLA 4</td> </tr> <tr> <td colspan="8">IEC 200 M/L 55</td> </tr> <tr> <td colspan="8">No</td> </tr> <tr> <td colspan="4"></td> <td colspan="2">Ins. cl. F</td> <td colspan="2">IP 55</td> </tr> <tr> <th>V</th> <th>Hz</th> <th>kW</th> <th>r/min</th> <th>A</th> <th>cos ϕ</th> <th>IA/IN</th> <th>IE/S</th> </tr> </thead> <tbody> <tr> <td>690 Y</td> <td>50</td> <td>30</td> <td>1475</td> <td>32.5</td> <td>0.83</td> <td></td> <td></td> </tr> <tr> <td>400 D</td> <td>50</td> <td>30</td> <td>1475</td> <td>56</td> <td>0.83</td> <td></td> <td></td> </tr> <tr> <td>660 Y</td> <td>50</td> <td>30</td> <td>1470</td> <td>34</td> <td>0.83</td> <td></td> <td></td> </tr> <tr> <td>380 D</td> <td>50</td> <td>30</td> <td>1470</td> <td>59</td> <td>0.83</td> <td></td> <td></td> </tr> <tr> <td>415 D</td> <td>50</td> <td>30</td> <td>1475</td> <td>54</td> <td>0.83</td> <td></td> <td></td> </tr> <tr> <td>440 D</td> <td>60</td> <td>35</td> <td>1770</td> <td>59</td> <td>0.83</td> <td></td> <td></td> </tr> <tr> <td colspan="8">Cat. no 3GAA 202 001 - ADA</td> </tr> <tr> <td colspan="2">6312/C3</td> <td colspan="2"></td> <td colspan="2">6210/C3</td> <td colspan="2">180 kg</td> </tr> <tr> <td colspan="8">IEC 34-1</td> </tr> </tbody> </table>		ABB Motors								3 ~ motor M2AA 200 MLA 4								IEC 200 M/L 55								No												Ins. cl. F		IP 55		V	Hz	kW	r/min	A	cos ϕ	IA/IN	IE/S	690 Y	50	30	1475	32.5	0.83			400 D	50	30	1475	56	0.83			660 Y	50	30	1470	34	0.83			380 D	50	30	1470	59	0.83			415 D	50	30	1475	54	0.83			440 D	60	35	1770	59	0.83			Cat. no 3GAA 202 001 - ADA								6312/C3				6210/C3		180 kg		IEC 34-1							
ABB Motors																																																																																																																									
3 ~ motor M2AA 200 MLA 4																																																																																																																									
IEC 200 M/L 55																																																																																																																									
No																																																																																																																									
				Ins. cl. F		IP 55																																																																																																																			
V	Hz	kW	r/min	A	cos ϕ	IA/IN	IE/S																																																																																																																		
690 Y	50	30	1475	32.5	0.83																																																																																																																				
400 D	50	30	1475	56	0.83																																																																																																																				
660 Y	50	30	1470	34	0.83																																																																																																																				
380 D	50	30	1470	59	0.83																																																																																																																				
415 D	50	30	1475	54	0.83																																																																																																																				
440 D	60	35	1770	59	0.83																																																																																																																				
Cat. no 3GAA 202 001 - ADA																																																																																																																									
6312/C3				6210/C3		180 kg																																																																																																																			
IEC 34-1																																																																																																																									
<p><input type="checkbox"/> Check that the motor data is correct. Values are predefined on the basis of the drive size but you should verify that they correspond to the motor.</p> <p>Start with the motor type. Go to the edit view of a selected row by pressing .</p> <ul style="list-style-type: none"> • Scroll the view with and . <p>Motor nominal $\cos\Phi$ and nominal torque are optional.</p> <p>Press (Next) to continue.</p>																																																																																																																									
<p><input type="checkbox"/> Adjust the limits according to your needs.</p> <ul style="list-style-type: none"> • Go to the edit view of a selected row by pressing . • Scroll the view with and . <p>Go to the next view by pressing (Next).</p>																																																																																																																									

<p><input type="checkbox"/> If you want to make a backup of the settings made so far, select Backup and press  (Next). If you do not want to make a backup, select Not now and press  (Next).</p>	 <p>Off  ACQ580 0.0 Hz</p> <p>Make backup?</p> <p>Copies all settings into a backup file stored in the control panel. To restore a backup, go to Menu > Backups.</p> <p>Backup</p> <p>Not now</p> <p>Back 12:10 Next</p>
<p><input type="checkbox"/> The first start is now complete and the drive is ready for use. Press  (Done) to enter the Home view.</p>	 <p>Off  ACQ580 0.0 Hz</p> <p>First start complete</p> <p>The drive is ready to run the motor. Press "Auto" to switch to external control.</p> <p>Start/Stop: DI1</p> <p>Reference (freq): AI1 scaled</p> <p>Back 12:11 Done</p>
<p><input type="checkbox"/> The Home view monitoring the values of the selected signals is shown on the panel.</p> <p>For changing the signals and their display style shown in the Home view, see <i>ACH-AP-x assistant control panels user's manual</i> (3AUA0000085685 [English]).</p>	 <p>Off  ACQ580 0.0 Hz</p> <p>Output frequency 0.00 Hz</p> <p>Motor current 0.00 A</p> <p>Motor torque 0.0 %</p> <p>12:11 Menu</p>

2 – Additional settings in the Primary settings menu

<p><input type="checkbox"/> Make any additional adjustments, for example, pump protections, starting from the Main menu – press  (Menu) to enter the Main menu. Select Primary settings and press  (Select) (or ).</p> <p>In the Primary settings menu, select Pump protections and press  (Select) (or ).</p> <p>To get more information on the Primary settings menu items, press  to open the help page.</p>	 <p>Off  ACQ580 0.0 Hz</p> <p>Main menu</p> <ul style="list-style-type: none">  Primary settings ▶  I/O ▶  Diagnostics ▶ <p>Exit 12:11 Select</p> <hr/> <p>Off  ACQ580 0.0 Hz</p> <p>Primary settings</p> <ul style="list-style-type: none"> Pump protections ▶ Ramps ▶ Pump cleaning ▶ PID control Not selected ▶ Pump control Off ▶ <p>Back 12:11 Select</p>
--	--

3 – Hand/Off/Auto operation

- The drive can be in remote control or local control, and in local control there are additionally two different modes.

Remote control: Drive is controlled from the I/O or the fieldbus.

- Top row of the view shows Auto.

Local control: Drive is controlled from the control panel.

- Top row of the view shows Off, that is, the drive is in the Off mode. Drive is stopped.
- Top row of the view shows Hand, that is, the drive is in the Hand mode. Drive is running. The initial reference in the Hand mode is copied from the drive reference.

Symbol \blacklozenge on the top row indicates that you can change the reference with \blacktriangle and \blacktriangledown .

The following diagram shows the state transitions when you press the Hand, Off or Auto button:

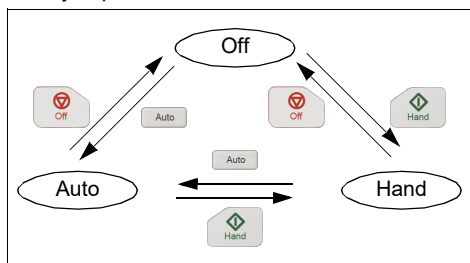

Note: When you restart the drive while fault 7081 Control panel loss is active, the mode changes from Hand or Off to Auto.

Auto	ACQ580	30.0 Hz
Output frequency	Hz	30.00
Motor current	A	0.46
Motor torque	%	8.9
	12:30	Menu
Off	ACQ580	0.0 Hz
Output frequency	Hz	0.00
Motor current	A	0.00
Motor torque	%	0.0
	12:37	Menu
Hand	ACQ580	30.0 Hz
Output frequency	Hz	30.00
Motor current	A	0.46
Motor torque	%	8.8
Reference	12:38	Menu
Off	ACQ580	0.0 Hz
Fault 7081		
Aux code: 0000 0000		
Control panel loss	12:41:43	
Control panel loss fault		
Hide	12:42	Reset

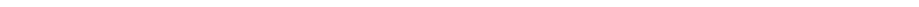

Power and productivity
for a better world™



EU Declaration of Conformity

Machinery Directive 2006/42/EC

We

Manufacturer: ABB Oy
Address: Hiomotie 13, 00380 Helsinki, Finland.
Phone: +358 10 22 11

declare under our sole responsibility that the following product:

Frequency converter

ACQ580-01/-31

with regard to the safety function

Safe torque off

is in conformity with all the relevant safety component requirements of EU Machinery Directive 2006/42/EC, when the listed safety function is used for safety component functionality.

The following harmonized standards have been applied:

EN 61800-5-2:2007	<i>Adjustable speed electrical power drive systems – Part 5-2: Safety requirements - Functional</i>
EN 62061:2005 + AC:2010 + A1:2013 + A2:2015	<i>Safety of machinery – Functional safety of safety-related electrical, electronic and programmable electronic control systems</i>
EN ISO 13849-1:2015	<i>Safety of machinery – Safety-related parts of control systems. Part 1: General requirements</i>
EN ISO 13849-2:2012	<i>Safety of machinery – Safety-related parts of the control systems. Part 2: Validation</i>
EN 60204-1: 2006 + A1:2009 + AC:2010	<i>Safety of machinery – Electrical equipment of machines – Part 1: General requirements</i>

The following other standards have been applied:

IEC 61508:2010	<i>Functional safety of electrical / electronic / programmable electronic safety-related systems</i>
IEC 61800-5-2:2016	<i>Adjustable speed electrical power drive systems – Part 5-2: Safety requirements - Functional</i>

The product referred in this Declaration of conformity fulfils the relevant provisions of other European Union Directives which are notified in Single EU Declaration of conformity 3AXD10000497692.

Person authorized to compile the technical file:

Name and address: Risto Myntinen, Hiomotie 13, 00380 Helsinki, Finland.

Helsinki, 10 Nov 2017

Manufacturer representative:

Vesa Kandell
Vice President, ABB Oy

Further information

Product and service inquiries

Address any inquiries about the product to your local ABB representative, quoting the type designation and serial number of the unit in question. A listing of ABB sales, support and service contacts can be found by navigating to www.abb.com/searchchannels.

Product training

For information on ABB product training, navigate to new.abb.com/service/training.

Providing feedback on ABB Drives manuals

Your comments on our manuals are welcome. Navigate to new.abb.com/drives/manuals-feedback-form.

Document library on the Internet

You can find manuals and other product documents in PDF format on the Internet at www.abb.com/drives/documents.



abb.com/drives



3AXD50000481873A